

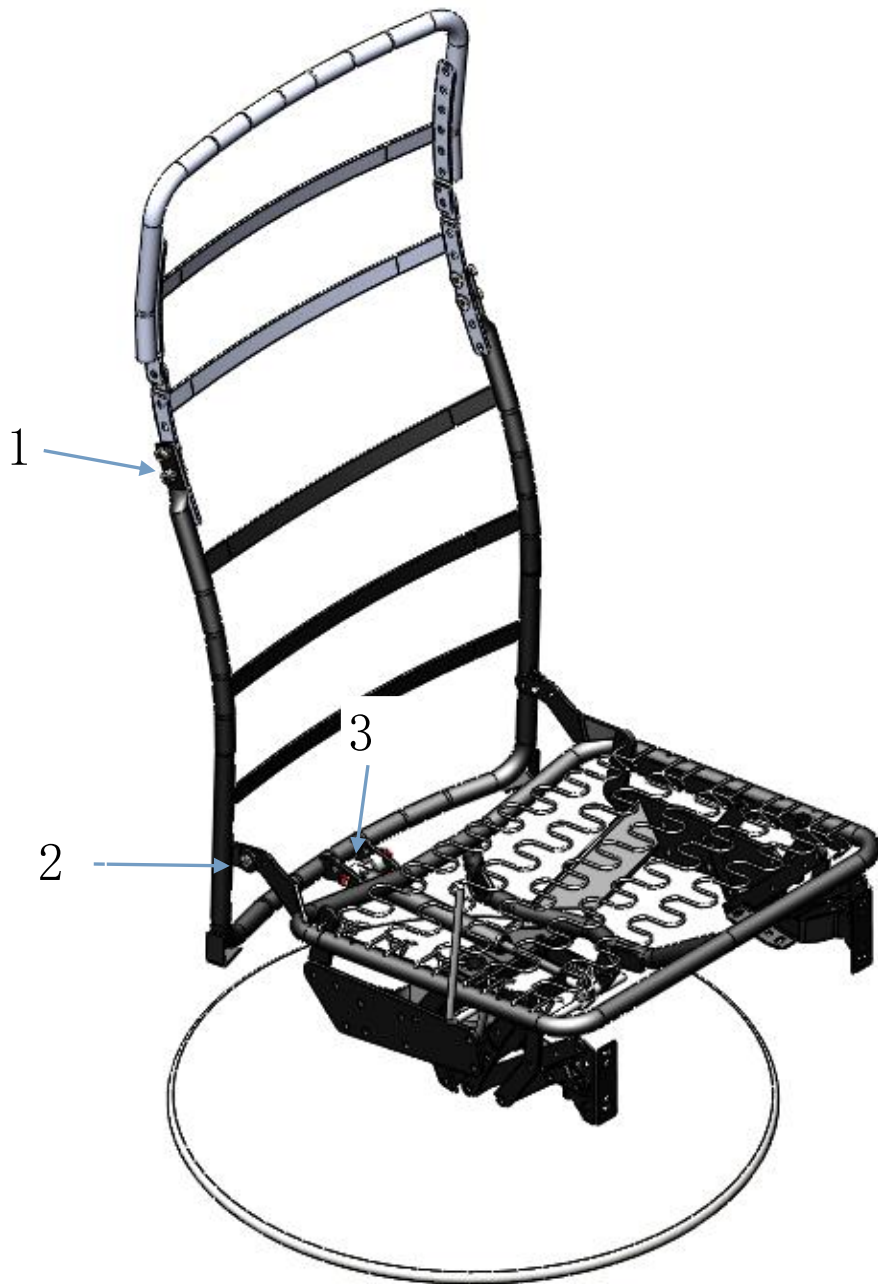

# 波恩-4630装配说明

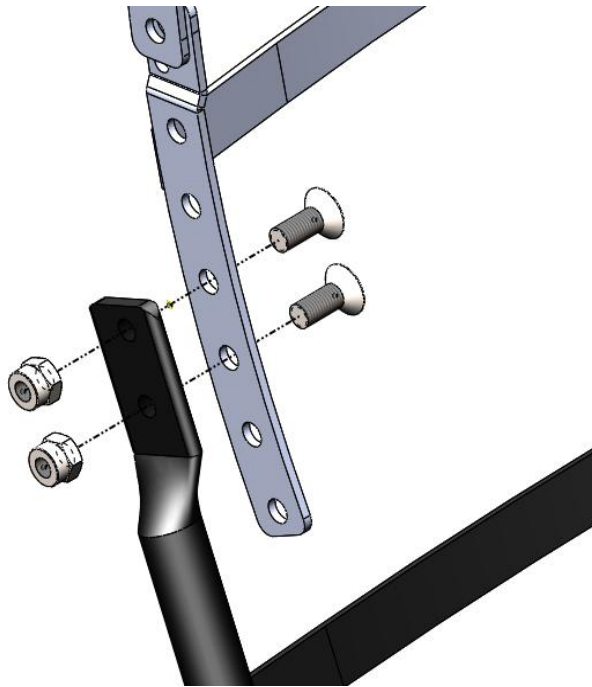

## 1. 靠背头部与背部连接

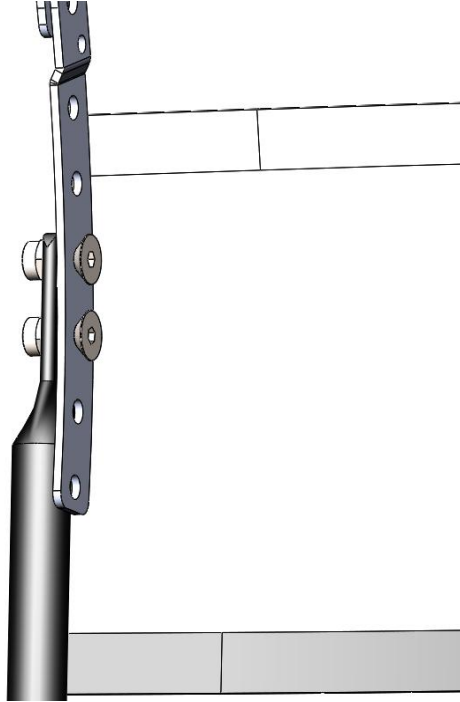

物料描述	图片	数量
内六角螺栓M8*20		4
防松螺母M8		4

## 2. 靠背与座框连接

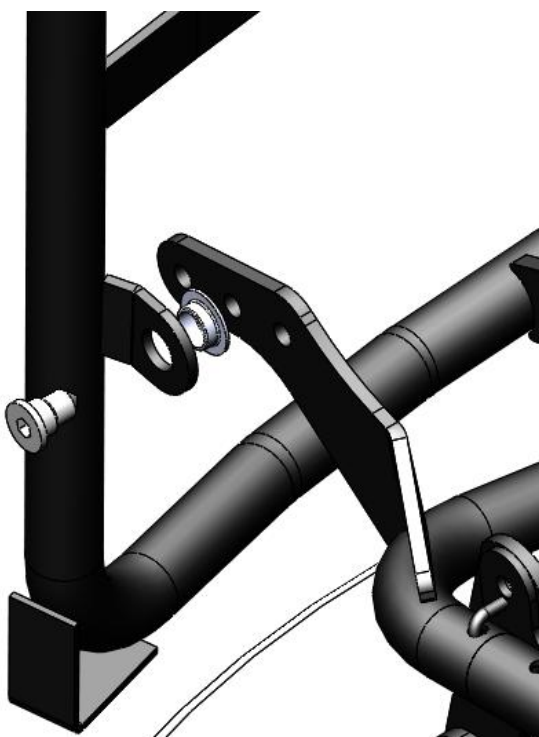

物料描述	图片	数量
内六角螺钉M8		2
带肩衬套 $\Phi 18 * \Phi 10 * 5$		2

### 3. 电机安装

